

环保物料

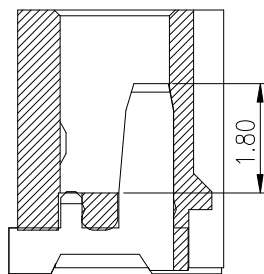

SECTION A-A
SCALE 1:1

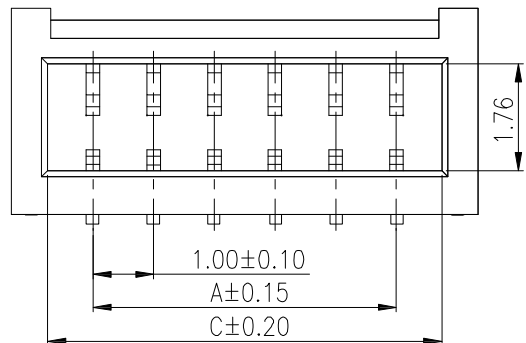
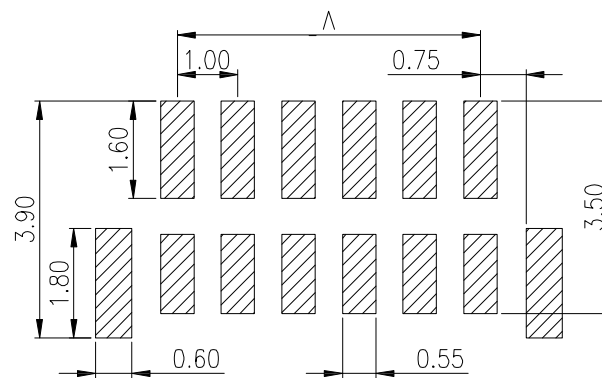
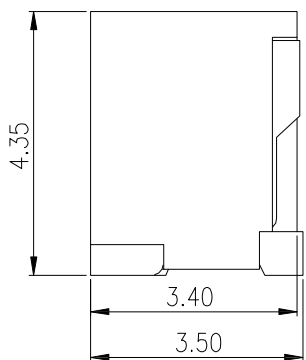
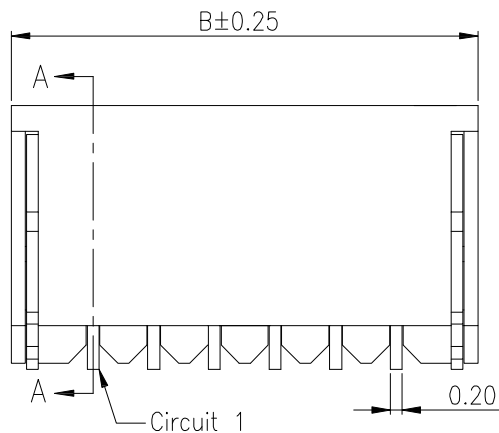

P.C.B Layout

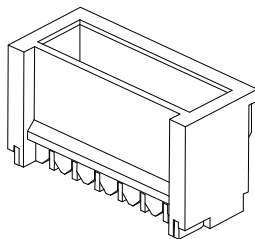
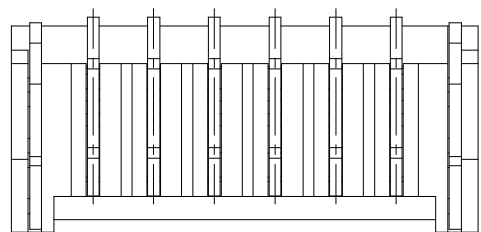

主要技术参数 Main Specifications

线 数 (Poles): 02 to 20
 接触电阻 (Contact resistance): $\leq 20m\Omega$
 绝缘电阻 (Insulation resistance): $\geq 100M\Omega$
 额定电压 (Rated voltage): 125V AC DC
 额定电流 (Rated current): 1.0A AC DC
 耐 电压 (Withstand Voltage): 500V AC/minute
 温度范围 (Temperature Range): $-25^{\circ}C \sim +85^{\circ}C$

Poles	Dimensions(mm)		
	A	B	C
02	1.00	3.70	2.50
03	2.00	4.70	3.50
04	3.00	5.70	4.50
05	4.00	6.70	5.50
06	5.00	7.70	6.50
07	6.00	8.70	7.50
08	7.00	9.70	8.50
09	8.00	10.70	9.50
10	9.00	11.70	10.50
11	10.00	12.70	11.50
12	11.00	13.70	12.50
13	12.00	14.70	13.50
14	13.00	15.70	14.50
15	14.00	16.70	15.50
16	15.00	17.70	16.50
17	16.00	18.70	17.50
18	17.00	19.70	18.50
19	18.00	20.70	19.50
20	19.00	21.70	20.50

ITEM	COMPONENT	Q'TY	MATERIAL	FINISH
C	SOLDER TAB	2 PCS	Brass	MATTE Sn-plated
B	CONTACT	n PCS	Brass	MATTE Sn-plated
A	HOUSING	1 PCS	Nylon9T	UL 94V-0, COLOR:Nature

REV.	REVISION RECORD	DATE	UNIT: MM	GENERAL TOLERANCES		SCALE: 1:1	NAME	DATE
				LINEAR	ANGLES			
A0	新图面发行	2017.06.16	MM	0.00±0.25	X° ±3°	APPROVED	黎腾	2017.06.16
	REVISION RECORD	DATE	SIZE: A4	0.000±0.15	X° X'±2°	DESIGNER	肖坤权	2017.06.16
						DRAWN	旷淇	2017.06.16

康导新能源
 网址: www.dgonne.com 电话: 0769-85337633
 邮箱: 2850175988@qq.com 传真: 0769-85392827

PART. NO:	21007AWW	
DWG. NO:		
REV:	A0	SHEET: 1/1