

环保物料

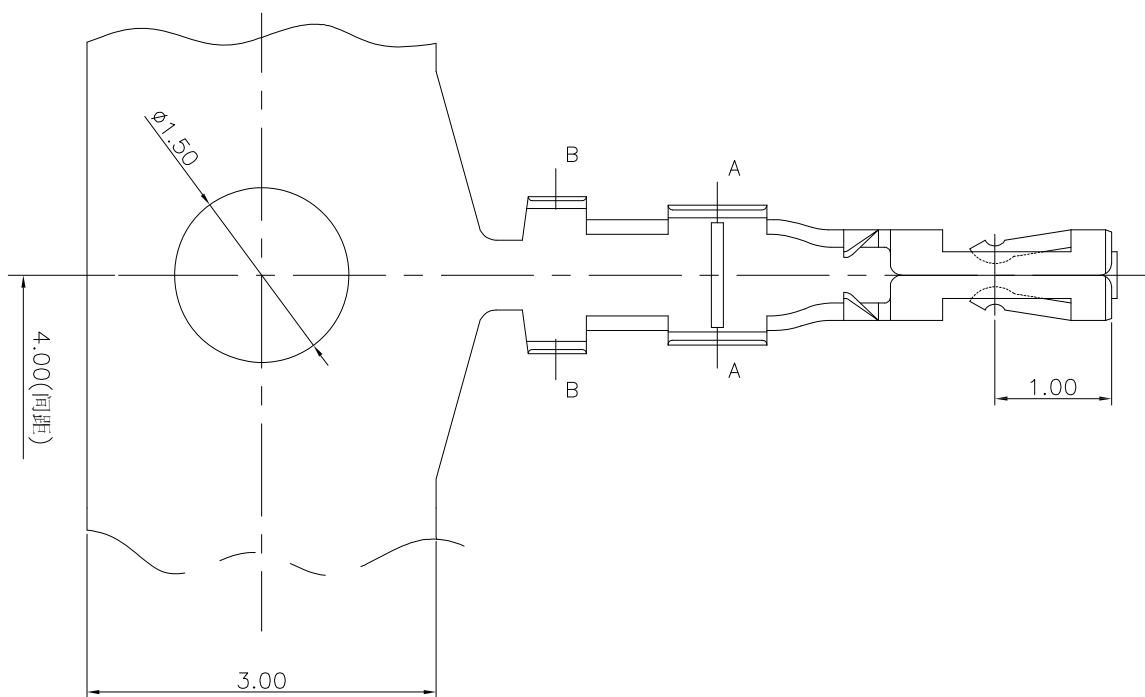

### 主要技术参数 Main Specifications

- 适用线规 (Applicable wire gauge): AWG28#~32#
- 接触电阻 (Contact resistance):  $\leq 20m\Omega$
- 绝缘电阻 (Insulation resistance):  $\geq 500M\Omega$
- 额定电压 (Rated voltage): 150V AC DC
- 额定电流 (Rated current): 1.0A AC DC
- 耐电压 (Withstand Voltage): 500V AC/minute
- 温度范围 (Temperature Range):  $-25^{\circ}C \sim +85^{\circ}C$

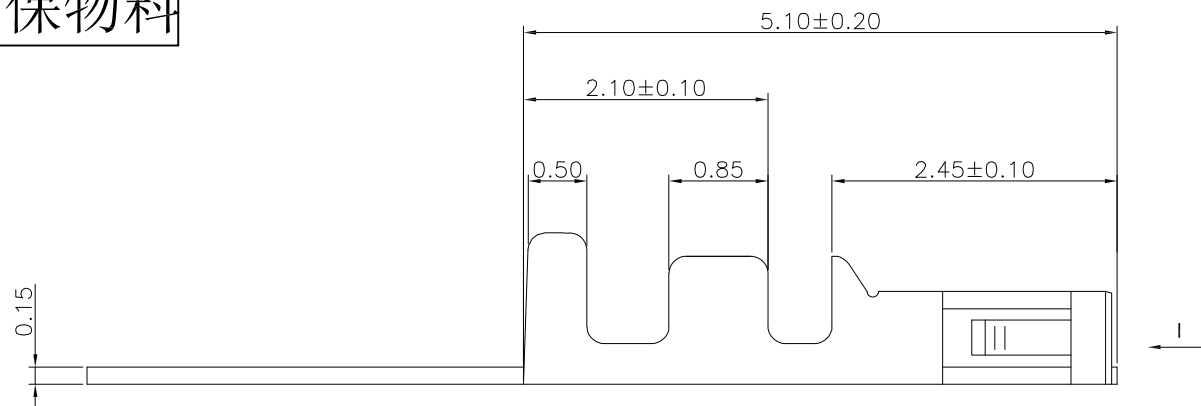
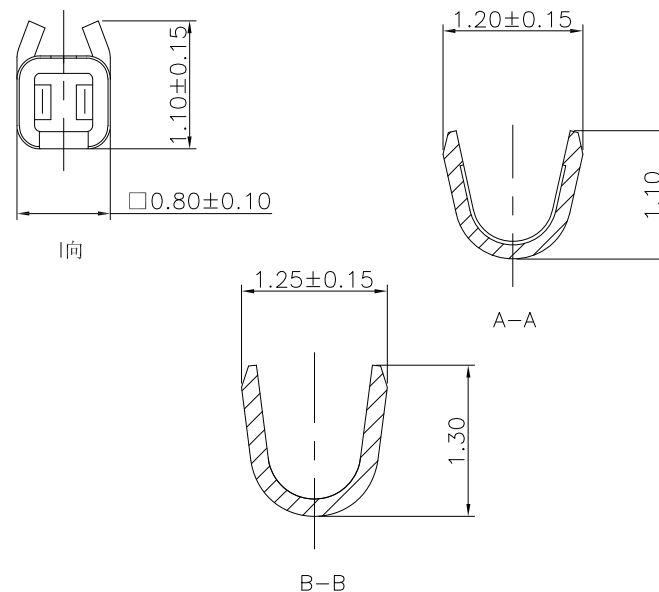

Wire Range	Insulation O.D.	Material	Finish	Qty/Reel
		Phosphor bronze	Tin-plated	

GENERAL TOLERANCES		SCALE: 1:1	NAME	DATE	康导新能源 网址: www.dgconne.com 电话: 0769-85337633 邮箱: 2850175988@qq.com 传真: 0769-85392827	PART. NO: 21255T
LINEAR	ANGLES					
0.0±0.35	X° REF±6°		黎腾	2017.06.16		DWG. NO:
0.00±0.25	X° ±3°		肖坤权	2017.06.16		REV: A0
0.000±0.15	X° X'±2°		旷淇	2017.06.16		SHEET: 1/1

REV.	REVISION RECORD	DATE	UNIT: MM	SIZE: A4
A0	新图面发行	2017.06.16		