

环保物料

Specifications:

Contact resistance:  $\leq 20m\Omega$   
 Insulation resistance:  $\geq 500M\Omega$   
 Rated voltage: 100V AC DC  
 Rated current: 2.0A AC DC (AWG#24)  
 Withstand Voltage: 500V AC/minute  
 Temperature Range:  $-40^{\circ}C \sim +105^{\circ}C$   
 Housing: LCP UL94V-0, Natural (Beige)  
 Contacts: Phosphor Bronze/Sn-plated  
 Solder Tabs: Brass/Sn-plated

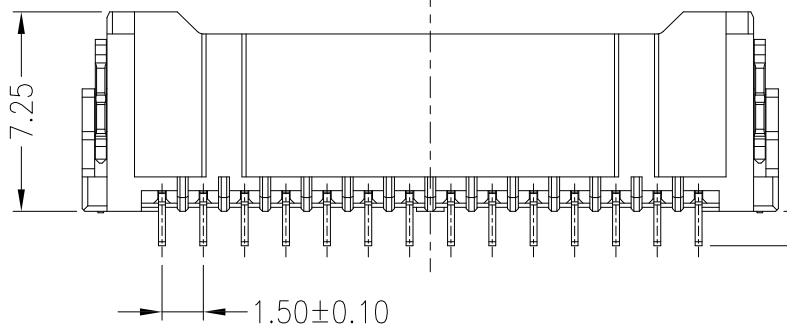
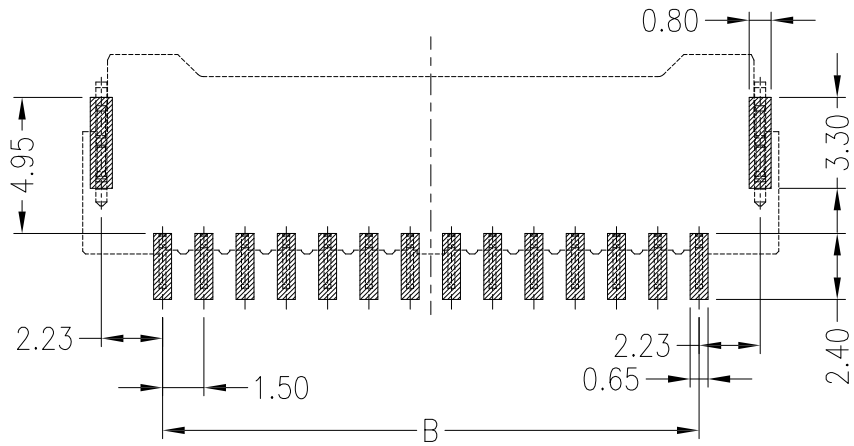
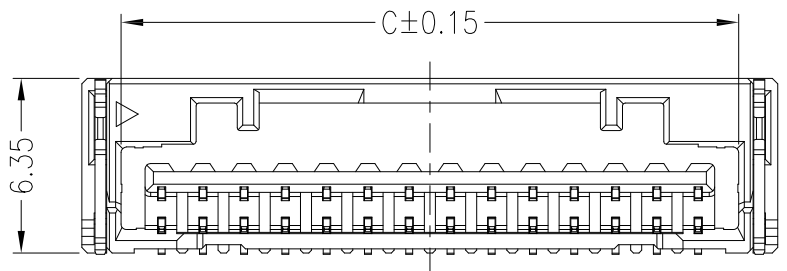
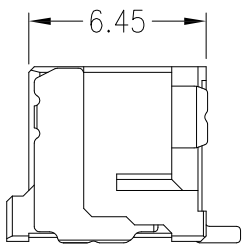
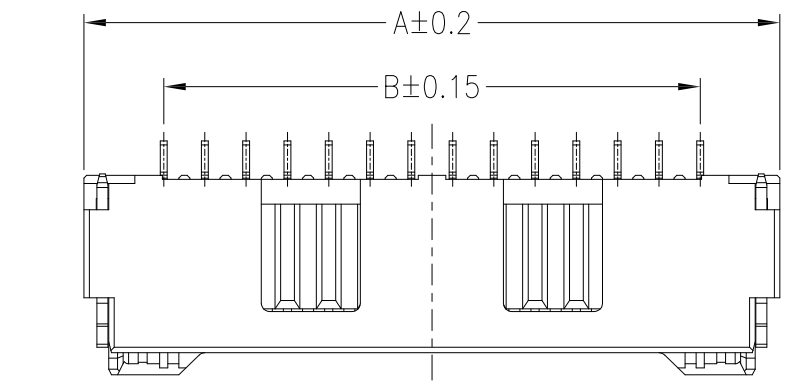

孔位	尺寸	A	B	C
* 2P		7.30	1.50	4.45
* 3P		8.80	3.00	5.95
* 4P		10.3	4.50	7.45
* 5P		11.8	6.00	8.95
6P		13.3	7.50	10.45
7P		14.80	9.00	11.95
8P		16.30	10.50	13.45
9P		17.80	12.00	14.95
10P		19.30	13.50	16.45
11P		20.80	15.00	17.95
12P		22.30	16.50	19.45
13P		23.80	18.00	20.95
14P		25.30	19.50	22.45
15P		26.80	21.00	23.95

		GENERAL TOLERANCES		SCALE: 1:1	NAME	DATE	康导新能源 网址: www.dgonne.com 电话: 0769-85337633 邮箱: 2850175988@qq.com 传真: 0769-85392827	PART. NO: 21506AWR	
				APPROVED	黎腾	2017.06.16		DWG. NO:	
				DESIGNER	肖坤权	2017.06.16			
A0	新图面发行	2017.06.16	UNIT: MM	0.00±0.25	X° ±3°			TITLE: 1.50mmPITCH 90° WAFER SMT TYPE	
REV.	REVISION RECORD	DATE	SIZE: A4	0.000±0.15	X° X'±2°	DRAWN	旷淇	2017.06.16	REV: A0 SHEET: 1/1