

环保物料

主要技术参数 Main Specifications

线数 (Poles): 02 to 16
 接触电阻 (Contact resistance): $\leq 20m\Omega$
 绝缘电阻 (Insulation resistance): $\geq 1000M\Omega$
 额定电压 (Rated voltage): 125V AC DC
 额定电流 (Rated current): 2.0A AC DC
 耐电压 (Withstand Voltage): 500V AC/minute
 温度范围 (Temperature Range): $-40^{\circ}C \sim +120^{\circ}C$

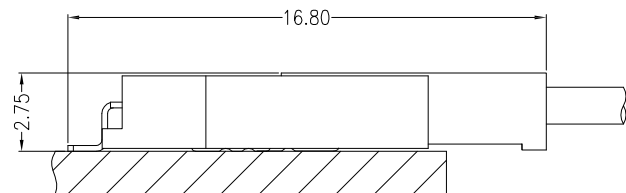
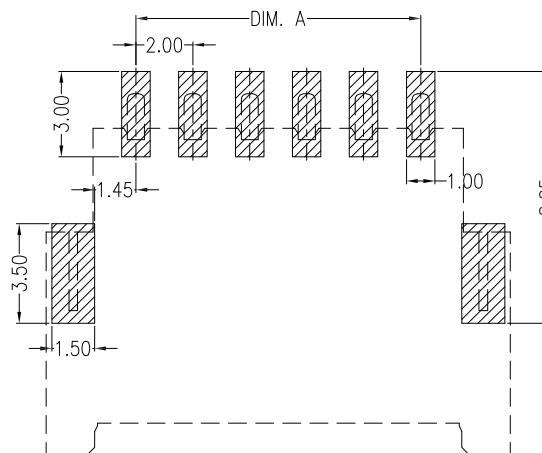
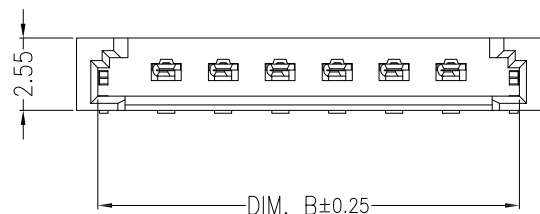
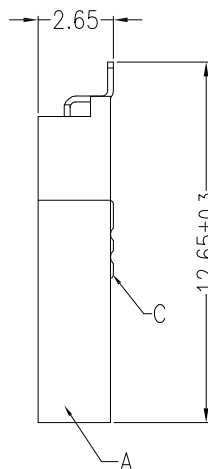
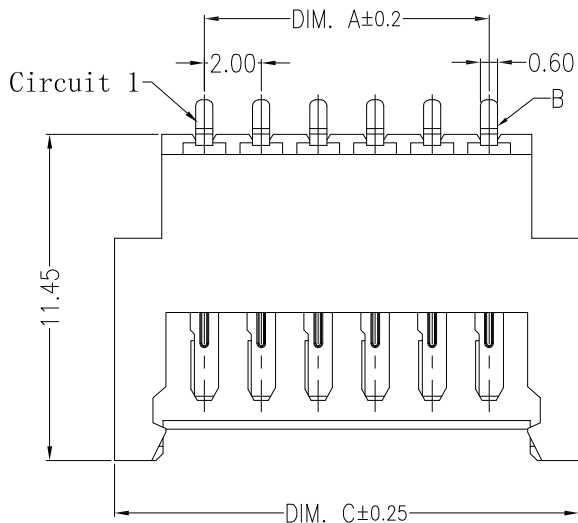
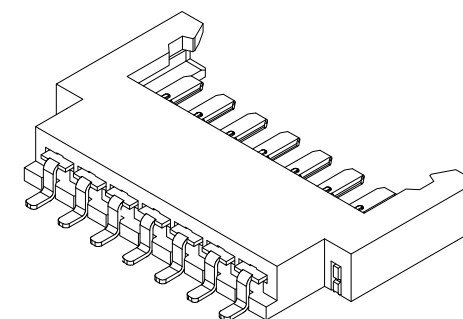

Assembly Layout

SUGGESTED PCB LAYOUT

Circuits	Dimensions (mm)		
	DIM. A	DIM. B	DIM. C
02	2.00	6.80	8.30
03	4.00	8.80	10.30
04	6.00	10.80	12.30
05	8.00	12.80	14.30
06	10.00	14.80	16.30
07	12.00	16.80	18.30
08	14.00	18.80	20.30

ITEM	COMPONENT	Q'TY	MATERIAL	FINISH
C	SOLDERTAB	2 PCS	Brass	Sn-plated
B	CONTACT	2~8 PCS	PhosphorBronze	MATTE Sn-plated
A	HOUSING	1 PCS	LCP	UL 94V-0, COLOR:BEIGE

GENERAL TOLERANCES		SCALE:	NAME	DATE	康导新能源 网址: www.dgonns.com 电话: 0769-85337633 邮箱: 2850176988@qq.com 传真: 0769-85392827	PART. NO: 22007AWR				
LINEAR	ANGLES	1:1	黎腾	2017.06.16						
0.0±0.35	X° REF±6°	APPROVED	肖坤权 <td>2017.06.16</td>	2017.06.16						
0.00±0.25	X° ±3°	DESIGNER	旷淇 <td>2017.06.16</td>	2017.06.16						
REV.	REVISION RECORD	DATE	UNIT: MM	SIZE: A4	0.000±0.15	X° X'±2°	DRAWN	TITLE: 2.00mmPITCH 90° WAFER SMT TYPE	REV: A0	SHEET: 1/1