

环保物料

主要技术参数 Main Specifications

线数 (Poles): 02 to 12
 接触电阻 (Contact resistance): $\leq 20m\Omega$
 绝缘电阻 (Insulation resistance): $\geq 1000M\Omega$
 额定电压 (Rated voltage): 250V AC DC
 额定电流 (Rated current): 3.0A AC DC
 耐电压 (Withstand Voltage): 1000V AC/minute
 温度范围 (Temperature Range): $-25^{\circ}C \sim +85^{\circ}C$

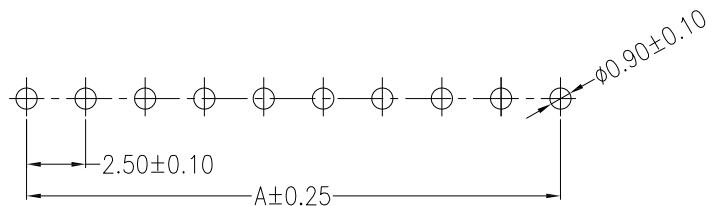
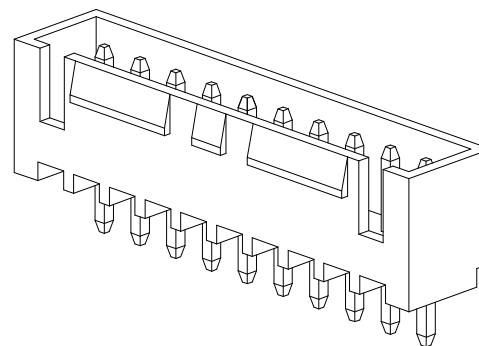
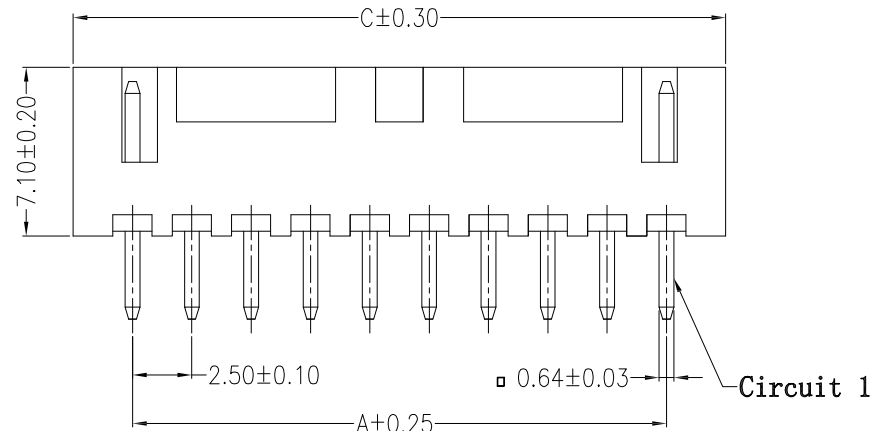
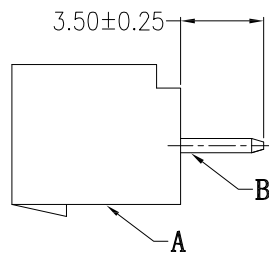
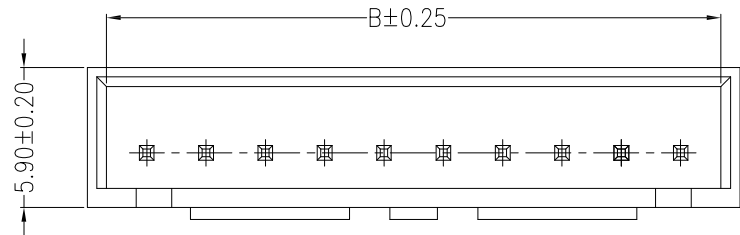

SUGGESTED PCB LAYOUT
(COMPONENT SIDE)

Circuits	Dimensions (mm)		
	A	B	C
02	2.50	6.00	7.50
03	5.00	8.50	10.00
04	7.50	11.00	12.50
05	10.00	13.50	15.00
06	12.50	16.00	17.50
07	15.00	18.50	20.00
08	17.50	21.00	22.50
09	20.00	23.50	25.00
10	22.50	26.00	27.50
11	25.00	28.50	30.00
12	27.50	31.00	32.50

ITEM	COMPONENT	Q'TY	MATERIAL	FINISH
B	CONTACT	2~12 PCS	Brass	Sn-plated
A	PEDESTAL	1 PCS	PA66	UL 94V-0, COLOR:WHITE

REV.	REVISION RECORD	DATE	UNIT: MM	SIZE: A4	GENERAL TOLERANCES	SCALE: 1:1	NAME	DATE	康导新能源 网址: www.dgonne.com 电话: 0769-85337633 邮箱: 2850176886@qq.com 传真: 0769-85392827	PART. NO: 22502A	DWG. NO:	REV: A0	SHEET: 1/1	
					LINEAR	ANGLES	APPROVED	黎腾						2017.06.16
					0.00±0.25	X° ±3°	DESIGNER	肖坤权						2017.06.16
					0.000±0.15	X° X'±2°	DRAWN	旷淇						2017.06.16
TITLE: 2.50mmPITCH 180° WAFER DIP TYPE														