

环保物料

主要技术参数 Main Specifications

线数 (Poles): 02~20
 接触电阻 (Contact resistance): $\leq 20m\Omega$
 绝缘电阻 (Insulation resistance): $\geq 1000M\Omega$
 额定电压 (Rated voltage): 250V AC DC
 额定电流 (Rated current): 3.0A AC DC
 耐电压 (Withstand Voltage): 1000V AC/minute
 温度范围 (Temperature Range): $-25^{\circ}C \sim +85^{\circ}C$

Poles	Dimensions mm	
	A	B
2	2.50	7.5
3	5.00	10.0
4	7.50	12.5
5	10.00	15.0
6	12.50	17.5
7	15.00	20.0
8	17.50	22.5
9	20.00	25.0
10	22.50	27.5
11	25.00	30.0
12	27.50	32.5
13	30.00	35.0
14	32.50	37.5
15	35.00	40.0
16	37.50	42.5
17	40.00	45.0
18	42.50	47.5
19	45.00	50.0
20	47.50	52.5

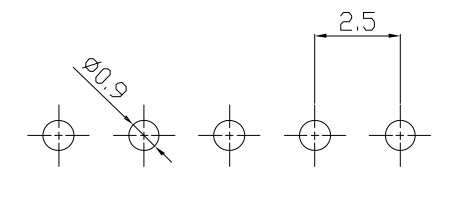
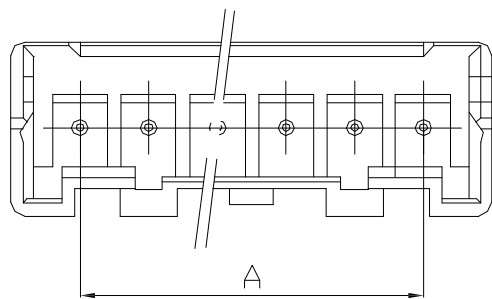
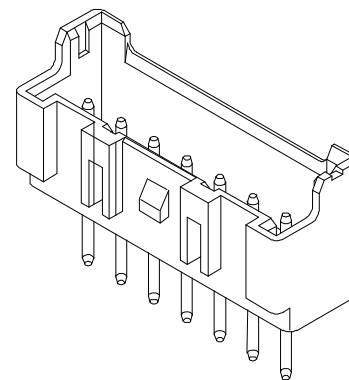
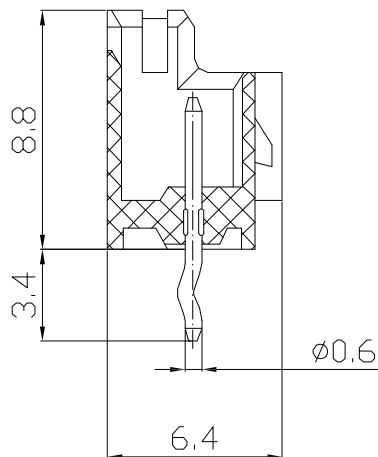
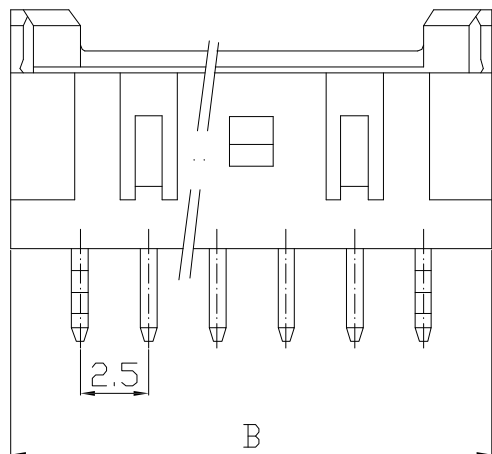

P. C. B LAYOUT

ITEM	COMPONENT	Q'TY	MATERIAL	FINISH
B	CONTACT	2~15 PCS	Brass	Tin-plated
A	PEDESTAL	1 PCS	PA66	COLOR:WHITE

REV.	REVISION RECORD	DATE	UNIT: MM	GENERAL TOLERANCES		SCALE: 1:1	NAME	DATE	康导新能源	PART. NO: 22506A
				LINEAR	ANGLES					
A0	新图面发行	2017.06.16	MM	0.00±0.25	X° ±3°	APPROVED	黎腾	2017.06.16	网址: www.dgonne.com 电话: 0769-85337633 邮箱: 2850176986@qq.com 传真: 0769-85392827	DWG. NO:
REV.	REVISION RECORD	DATE	SIZE: A4	0.000±0.15	X° X'±2°	DESIGNER	肖坤权	2017.06.16	TITLE: 2.50mmPITCH 180° WAFER DIP TYPE	REV: A0 SHEET: 1/1



康导新能源
 网址: www.dgonne.com 电话: 0769-85337633
 邮箱: 2850176986@qq.com 传真: 0769-85392827

PART. NO:
22506A

DWG. NO:

REV: A0 SHEET: 1/1