

环保物料

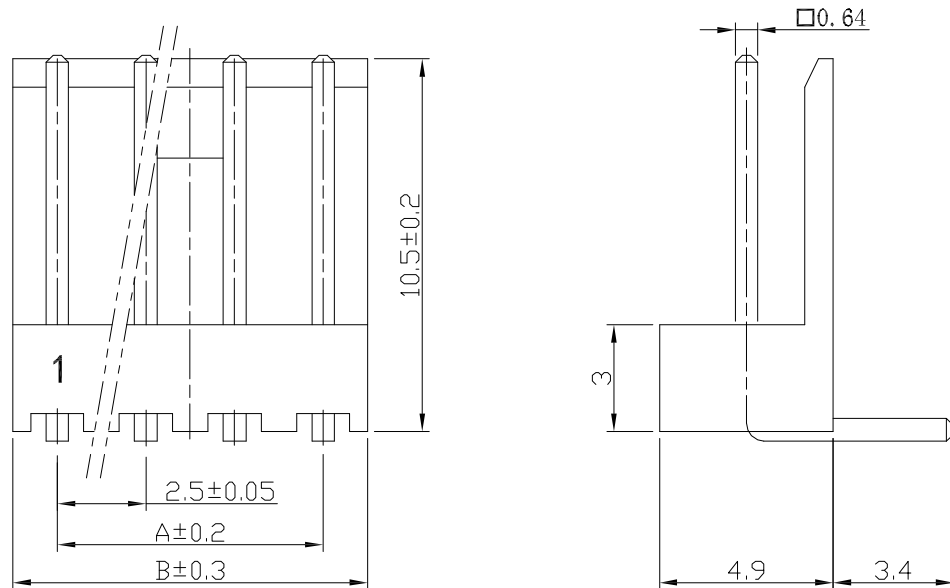

主要技术参数 Main Specifications

线 数 (Poles): 02 to 24
 接触电阻 (Contact resistance): $\leq 20m\Omega$
 绝缘电阻 (Insulation resistance): $\geq 1000M\Omega$
 额定电压 (Rated voltage): 250V AC DC
 额定电流 (Rated current): 2.5A AC DC
 耐 电 压 (Withstand Voltage): 1000V AC/minute
 温度范围 (Temperature Range) : $-25^{\circ}\text{C} \sim +85^{\circ}\text{C}$

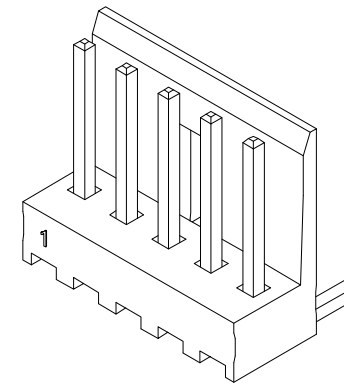

Poles	Dimensions mm	
	A	B
2	2.50	5.00
3	5.00	7.50
4	7.50	10.00
5	10.00	12.50
6	12.50	15.00
7	15.00	17.50
8	17.50	20.00
9	20.00	22.50
10	22.50	25.00
11	25.00	27.50
12	27.50	30.00
--	--	--
24	57.50	60.00

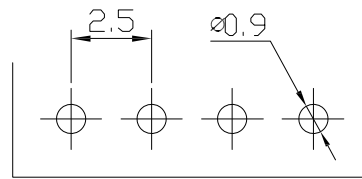

P. C. B LAYOUT

ITEM	COMPONENT	Q'TY	MATERIAL	FINISH
B	CONTACT	n PCS	Brass	Tin-plated
A	PEDESTAL	1 PCS	PA66	COLOR:WHITE

REV.	REVISION RECORD	DATE	UNIT: MM	GENERAL TOLERANCES		SCALE: 1:1	NAME	DATE
				LINEAR	ANGLES			
A0	新图面发行	2017.06.16	MM	0.00±0.25	X° ±3°	APPROVED	黎腾	2017.06.16
			SIZE: A4	0.000±0.15	X° X'±2°	DESIGNER	肖坤权	2017.06.16
						DRAWN	旷淇	2017.06.16

康 导 新 能 源
 网址: www.dgonns.com 电话: 0769-85337633
 邮箱: 2850175988@qq.com 传真: 0769-85392827

PART. NO:	22510AW	
DWG. NO:		
REV:	A0	SHEET: 1/1