

环保物料

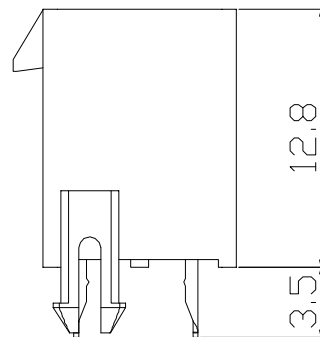

主要技术参数 Main Specifications

线数 (Poles): 02 to 24
 接触电阻 (Contact resistance): $\leq 15m\Omega$
 绝缘电阻 (Insulation resistance): $\geq 1000M\Omega$
 额定电压 (Rated voltage): 300V AC DC
 额定电流 (Rated current): 9.0A AC DC
 耐电压 (Withstand Voltage): 1500V AC/minute
 温度范围 (Temperature Range): $-25^{\circ}C \sim +85^{\circ}C$

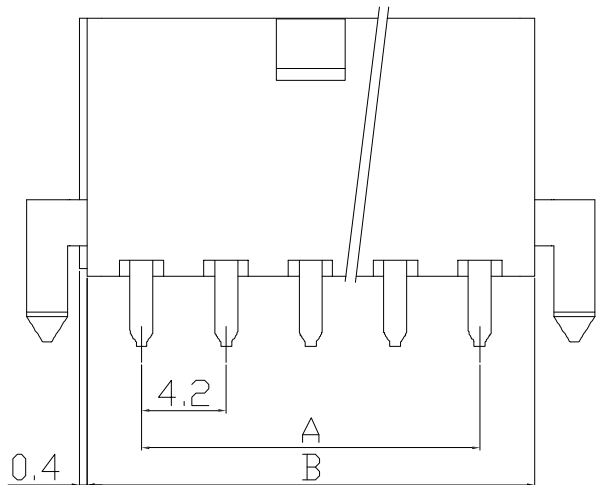
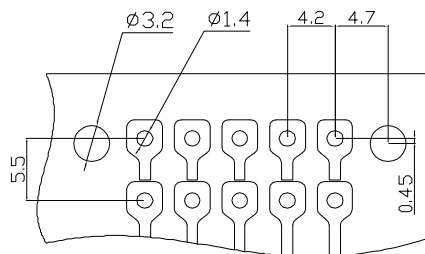
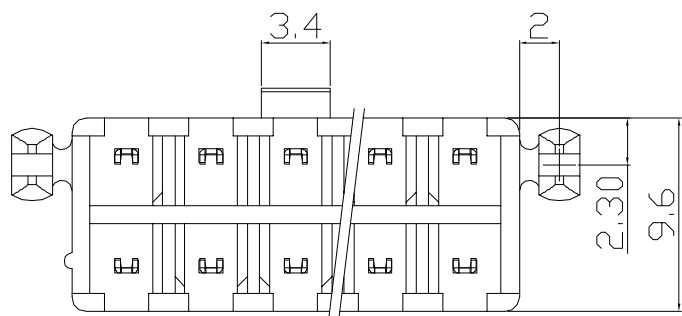

PCB Layout

Poles	Dimensions mm	
	A	B
2		5.40
4	4.20	9.60
6	8.40	13.80
8	12.60	18.00
10	16.80	22.20
12	21.00	26.40
14	25.20	30.60
16	29.40	34.80
18	33.60	39.00
20	37.80	43.20
22	42.00	47.40
24	46.20	51.60

2	Wafer 针	Brass Tin 黄铜镀锡	N	
1	Housing 基座	PA66 (UL94V-0/V-2)	1	White (白色)
序号	图号	名称	材料	数量 附注

GENERAL TOLERANCES		SCALE: 1:1	NAME	DATE	康导新能源 网址: www.dgconne.com 电话: 0769-85337633 邮箱: 2850175986@qq.com 传真: 0769-85392827	PART. NO: 24201AD2	
LINER	ANGLES	APPROVED	黎腾	2017.06.16		DWG. NO:	
0.00±0.35	X° REF±6°	DESIGNER	肖坤权	2017.06.16		REV: A0 SHEET: 1/1	
0.00±0.25	X° ±3°	DRAWN	旷淇	2017.06.16		TITLE: 4.20mmPITCH 180° WAFER DIP TYPE	
REV.	REVISION RECORD	DATE	UNIT: MM	SIZE: A4	0.000±0.15	X° X'±2°	