

# 环保物料

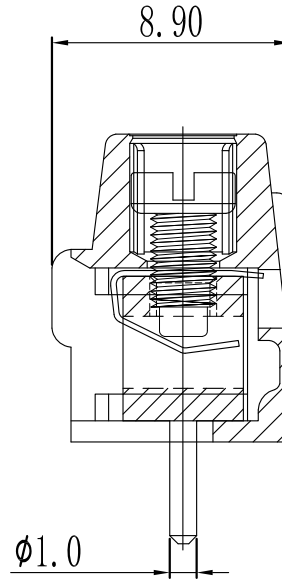
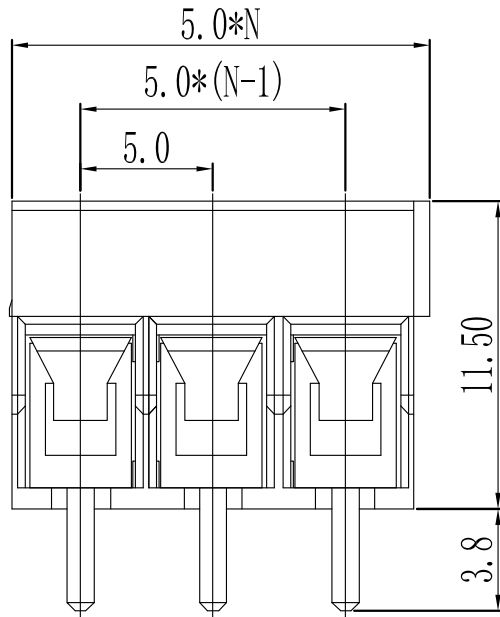
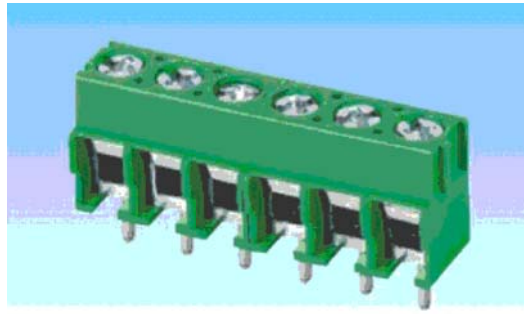

N=Number of Contacts

产品型号	MODEL	KD170V
材质&电镀	MATERIAL&PLATING	
螺丝	Screw	M2.5, 钢, 镀锌 steel, Zinc Plated
弹片	Reed	黄铜, 镀镍 Brass, Ni plated
焊针	Pin header	黄铜, 镀锡 Brass, Tin plated
塑件	Housing	PA66, UL94V-0
电气性能	ELECTRICAL	UL IEC
额定电压	Rated voltage	300V 250V
额定电流	Rated current	10A 25A
接触电阻	Contact resistance	20mΩ
绝缘电阻	Insulation resistance	500MΩ/1000V
耐电压	Withstanding voltage	AC2000V/1min
使用线径	Wire range	26-14AWG 2.5mm <sup>2</sup>
机械性能	MECHANICAL	
温度范围	Temp. range	-40℃~+105℃
瞬时温度	Max. soldering	+250℃, 5sec
扭矩	Torque	0.4N.m 3.5Lb.in
剥线长度	Strip length	5-6mm

				GENERAL TOLERANCES		SCALE: 1:1	NAME	DATE	 网址: www.dgonne.com 电话: 0769-85337633 邮箱: 2850176886@qq.com 传真: 0769-85392827	PART. NO:	KDTB0028
				LINEAR	ANGLES	APPROVED	黎腾	2017.06.16		DWG. NO:	
A0	新图面发行	2017.06.16	UNIT: MM	0.00±0.25	X° ±3°	DESIGNER	肖坤权	2017.06.16	TITLE:	Pitch 5.00mm Euro Terminal Blocks	
REV.	REVISION RECORD	DATE	SIZE: A4	0.000±0.15	X° X'±2°	DRAWN	旷淇	2017.06.16	REV:	A0	SHEET: 1/1