

环保物料

产品型号	MODEL	KD12HWP
材质&电镀	MATERIAL&PLATING	
螺丝	Screw	M3.5, 钢, 镀锌 Steel, Zinc Plated
端子	Terminal	黄铜, 镀镍 Brass, Nickel plated
塑件	Housing	Nylon PA66, UL94V-2
电线保护装置	Wire protector	不锈钢 Stainless Steel
电气性能	ELECTRICAL	
额定电压	Rated voltage	500V
测试电流	Test current	to EN 60998:57A
使用线径	Wire range	2.5-6.0mm <sup>2</sup>
机械性能	MECHANICAL	
温度范围	Temp. range	-40°C~+110°C
产品编号	Product number code	KD12HWP-XP
底座高	High base	H
-	XP	No. of pole 1...12:1pole...12pole
-	WP	保护器 With wire protector

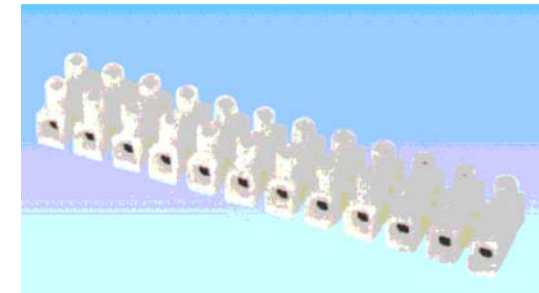
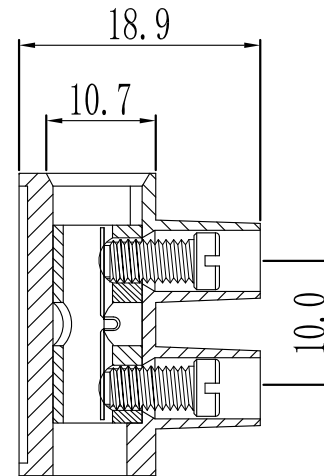
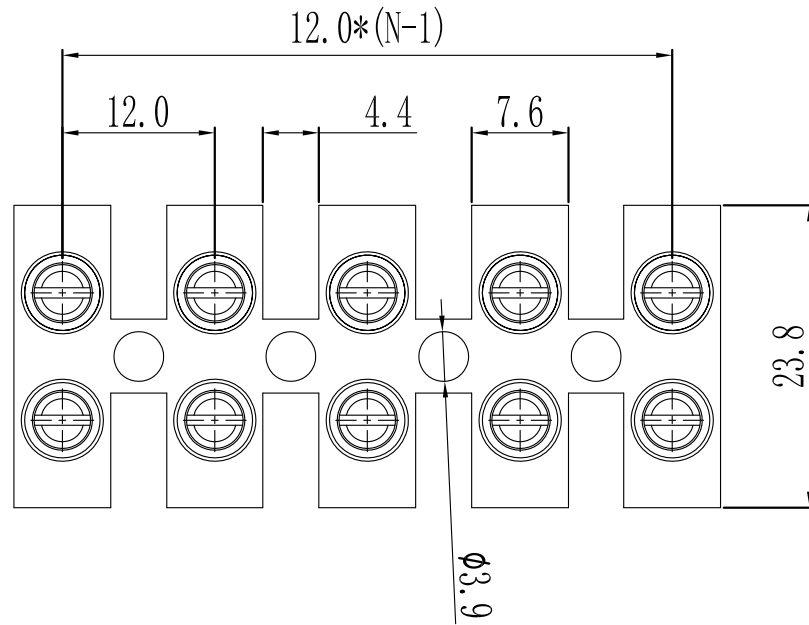

N=Number of Contacts

		GENERAL TOLERANCES		SCALE: 1:1	NAME	DATE	康导新能源 网址: www.dgonne.com 电话: 0789-8537833 邮箱: 2850178888@qq.com 传真: 0789-85392827	PART. NO:	
		LINEAR	ANGLES	APPROVED	黎腾	2017.06.16		KDTB0187	
A0	新图面发行	2017.06.16	UNIT: MM	0.00±0.25	X° ±3°	DESIGNER	肖坤权	2017.06.16	DWG. NO:
REV.	REVISION RECORD	DATE	SIZE: A4	0.000±0.15	X° X'±2°	DRAWN	旷淇	2017.06.16	REV: A0 SHEET: 1/1